

Part List – (Parts included in ISL adder kit, OE and IC base kits)

Part	Part #	Description	Qty.
A	11-5432720	Back Support Bracket	2
B	11-5431720	Front Support Bracket	2
C	65-19555	#10 -3/8" F-type Screw	14
D	40-3268600	Shoulder Bolt (Male)	3
E	40-3268590	Shoulder Bolt (Female)	3
F	11-972XX1-S	Solid Plastic Slope Top	2
G	65-22637	Angle Bracket "L"	6
H	11-8030X1	Phenolic Support Block	6
*	65-19565	Drill Bit #19 (.165" dia.)	1

Recommended Tools:

T25 torx bit, T27 pin torx bit, .165" drill bit (Included), .25" drill bit, Miter Saw, and Cordless Drill

Step 1

- Measure run of lockers to determine if cuts are required for the back (A) and the front (B) extruded aluminum slope supports.

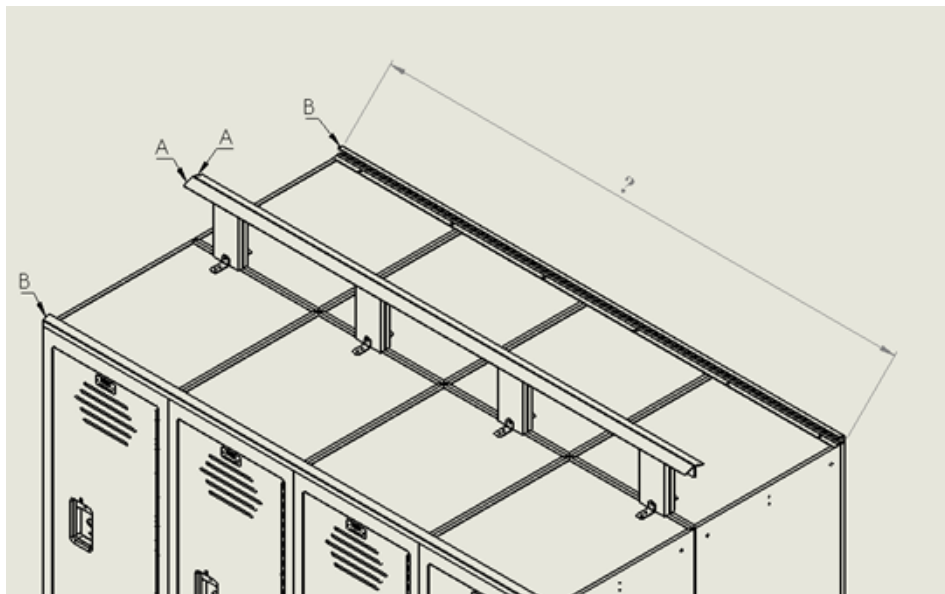

Step 2

- Install the front (B) supports using the supplied fasteners (C)
- The aluminum supports should be cut to required length to finish the run. Supports should cover the entire length of the lockers and not protrude past the locker sides.

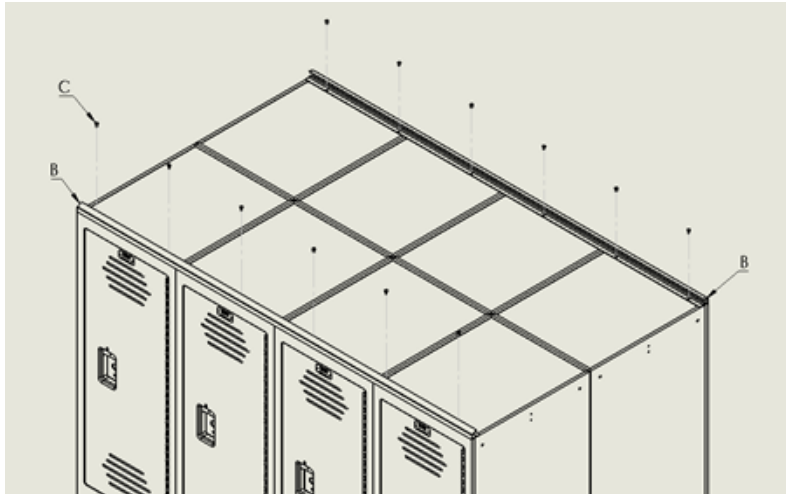

Pre-drill holes using the supplied #19 drill bit .165" dia. x .44" deep in the locker top to accept screws (C)

Step 3

- Attach the short leg of the angle brackets (G) to Support block (H) using screws (C)
- Attach 6-support blocks per ea. 72" run to support the back support brackets using screws (C)

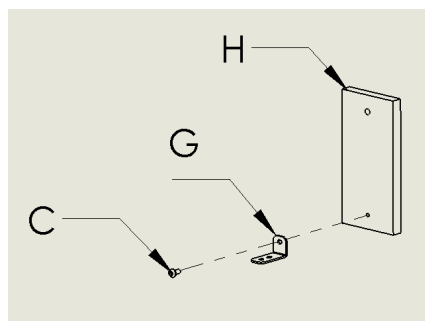

CAUTION

Be careful not to drill into the sides of the the locker when installing extrusions. Drill new holes in extrusion, if it falls on the seam.

Do not over-tighten screws

- Mark and pre-drill holes into top of locker to attach support blocks with angle brackets (6 pairs per each 72" run). Use 0.165" drill bit provided.
- Leave room between the support blocks (H) to slide the support brackets (A) between them as seen below. Attach angle brackets(G) to locker top using screws (C).

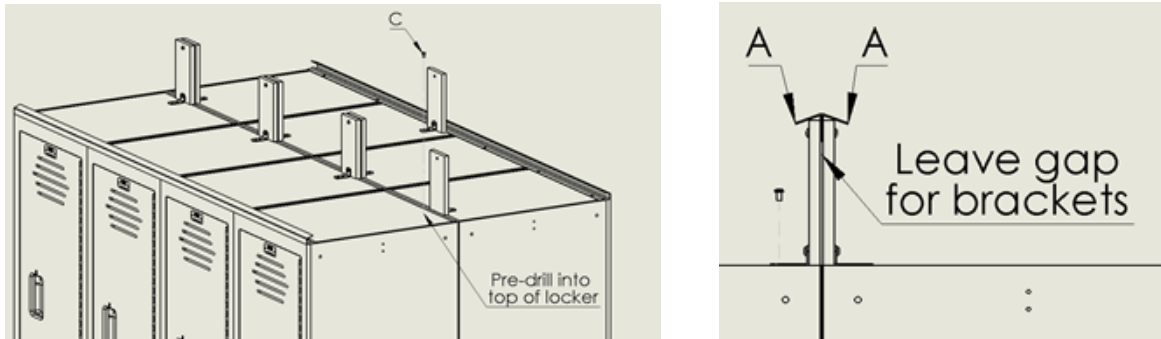

Step 4

- After support blocks are installed, place the two back supports together and slide down in between the support blocks.
- Make sure ends of the back supports are flush with each other and with the side of the lockers.
- Press down firmly and drill a .25" dia. hole thru back supports (A).
- Install shoulder bolts (D & E) to secure back supports to support blocks.

